

[Home](#) ■ [Products](#) ■ [Screenings Treatment](#)

HUBER Screenings Wash Press WAP® SL



Super Launder Wash Press

- volume, weight and disposal cost reduction of up to 85%
- compaction up to 50% DR
- high washed screenings quality of < 20mg BOD₅ / g DR
- Feeding through a launder channel or directly from a screen or conveyor

The WAP® SL operates in a batch mode. Screenings either drop into the launder tank directly from a screen or conveyor, or they are flushed into the tank through a launder channel. After a batch of screenings has been fed, the tank is filled up with wash water and agitated for an adjustable period by means of an impeller. The fecal matter is loosened and removed from the screenings by high turbulence and shear.

After the washing cycle has been finished, an automatic valve opens and the wash water drains through perforations in the trough. It returns, together with the fecal matter, to the wastewater flow. A screw in the trough conveys the screenings towards the mouth of a tube whereby they are, as an additional option, rinsed with spray water. The screw pushes the screenings through the pressure zone where they are compressed, dewatered and compacted before they are finally discharged through the discharge pipe into a dumpster or bagger.

Benefits

THE ADVANTAGES OF THE HUBER SCREENINGS WASH PRESS WAP® SL

- High-intensity washing in launder tank
- Washed screenings quality < 20 mg BOD₅ / g DR
- Compaction up to 50 % DS
- Volume, weight and disposal cost reduction by up to 85 %
- Screenings processing capacity of 2 - 12 m³/h (70 - 420 ft³/hr)
- Screen wastewater or process water can be used as wash water
- Sturdy design
- All structural parts, including the screw, are made of stainless steel to prevent electrochemical corrosion
- Fast payback due to great transportation and disposal cost savings

Downloads

 [Brochure: HUBER Screenings Wash Press WAP/SL](#) [pdf, 239 KB]

Case Studies

- [A Wastewater Screening and Screenings Processing Case Study at WWTP Hull \(Saltend\)](#)
- [Huber Technology upgrades the Inlet works at Duncrue Street, Belfast - a Wastewater case Study](#)
- [A successful combination: Launder Channel plus Wash Press SL](#)
- [Huber Screenings and Sludge Treatment Equipment in Northern Ireland](#)
- [Great HUBER Bar Screens and Wash-Presses in Dublin](#)
- [HUBER super-launder wash-press excels at Penrith WWTP](#)
- [Perforated Band Screens EscaMax® for Anglian Water](#)
- [Well Received Septic Sludge in Finland](#)
- [HUBER Super-Launder Wash Presses WAP/SL Excel at Chelmsford WWTP](#)

Design Sketch

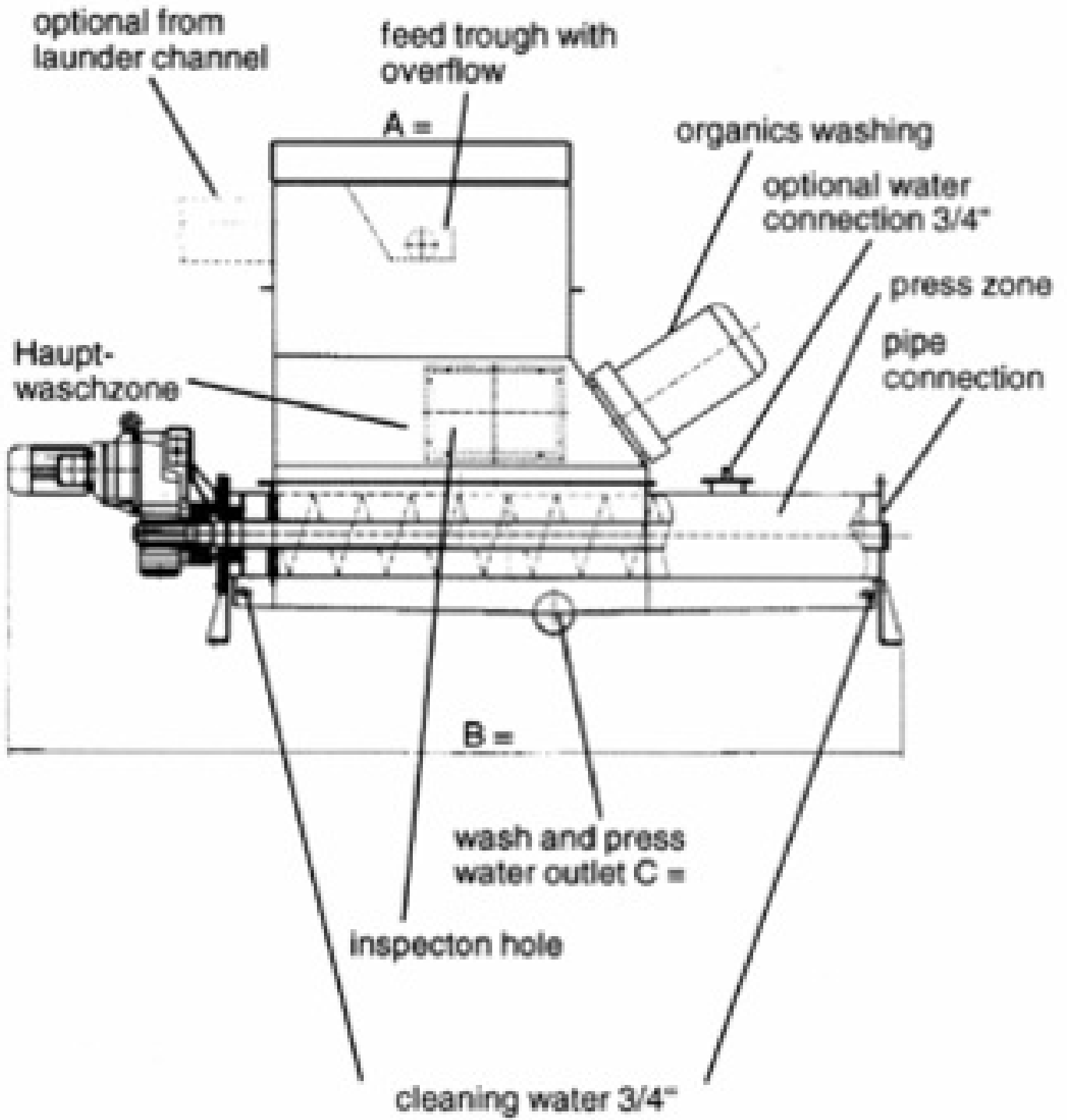

Media





Video: Screenings Wash Press WAP/SL at a municipal WWTP
https://www.youtube.com/watch?v=vylieOQUR_9o

More products of this group: Screenings Treatment

- [Screenings Wash Press WAP®](#)
- [Screenings Wash Press WAP® SL HP](#)
- [Screenings Wash Press WAP® L for Launder Channel Feeding](#)
- [HUBER Launder Channel HLC](#)
- [HUBER Screw Conveyor Ro8 / Ro8 T](#)
- [HUBER Screenings Compactor Ro7](#)
- [Integrated Screenings Washing](#)

Adresse / address: HUBER SE · Industriepark Erasbach A1 · 92334 Berching · Germany · Telefon / phone: + 49 - 84 62 - 201 - 0 · Fax / fax: + 49 - 84 62 - 201 - 810
e-mail: info@huber.de · Internet: <http://www.huber.de>

Sitz der Gesellschaft / Headquarters: Berching · AG Nürnberg / Register of companies: HRB 25558
Vorstand / Board: Georg Huber (Vorsitzender / CEO), Dr.-Ing. Oliver Rong (stellvertretender Vorsitzender / Vice CEO), Dr.-Ing. Johann Grienberger, Rainer Köhler
Aufsichtsratsvorsitzender / Chairman of the Supervisory Board: Alois Ponnath



USt (VAT)-IdNr.: DE 812353219
Bank: HypoVereinsbank Nürnberg (BLZ 760 200 70) 5 008 409 · SWIFT-BIC: HYVEDEMM460 · IBAN: DE 30 7602 0070 0005 0084 09

